

**European Sustainable Energy Communities - effective
Integrated Local Energy Action today
(Sustainable NOW)
(Contract number – IEE/07/752/SI2.499210)**

Deliverable: D3.3

Study on financial aspects of projects

Prepared by: Marco Bianchi, Adriano Pallaro (Banca Popolare Etica)

Checked by: Marco Bianchi (Banca Popolare Etica), Daniel Morchain (ICLEI)

31st August 2011

Contributors: Banca Popolare Etica, ICLEI, Climate Alliance, Coordinamento Agenda 21 Italiane, Ecovision, Trecodome, Municipality of Bourgas, City of Ludwigsburg, City of Munich, City of Miskolc, Comunità Montana – Associazione dei Comuni Trasimeno – Medio Tevere, City of Bologna, Province of Siena, City of Rosignano Marittimo, Woking Borough Council.

A thanks to Francesca Brazzale.

Contents:

1 – THE “SUSTAINABLE NOW” PROJECT	page 3
2 – CONTEXT OF THE STUDY	page 4
3 – SCREENING OF FINANCIAL OPPORTUNITIES	page 6
4 – COST/BENEFIT ANALYSIS	page 21
5 – BEST PRACTICES	page 28
6 – VALUE FOR MONEY ASSESSMENT	page 40
7 – FINANCIAL PLANNING OF PROJECTS	page 42
8 – CHECK LIST	page 46

The sole responsibility for the content of this publication etc. lies with the authors. It does not necessarily reflect the opinion of the European Union.

The European Commission is not responsible for any use that may be made of the information contained therein.

1

THE “SUSTAINABLE NOW” PROJECT

Sustainable NOW Project, coordinated by ICLEI - Local Governments for Sustainability, involves 15 partners from seven EU countries. It aims to contribute to the development of Energetically Sustainable Communities in Europe, strengthening the role of local authorities in their capacity as administrators and policy makers of a territory, supporting their commitment to act in order to become reference points for other communities and inspiring them in the path towards sustainable energy.

The goal is to create an enabling environment to ensure the success of the undertaken actions and the achieving of ambitious energy targets and of reduction of emissions. The main benefits for the communities (local governments and stakeholders of an area) consist of an increase in skills and use of new tools for the development, implementation and evaluation of the concept of energetically sustainable communities.

The project is co-funded by the European Commission under the Intelligent Energy Programme (IEE); it began in September 2008 and it will end in August 2011.

The Sustainable NOW consortium is composed of expert and novice communities in the field of energy, network of local governments and technical experts. Each partner contributes with its own specific expertise and plays a defined role.

Banca Popolare Etica is configured as a technical partner of the project. It is the first financial institution in Italy to base its investments on the principles of ethical finance and it has a wide experience in financing projects for sustainable energy; it is associated with the European Federation of Ethical and Alternative Banks (FEBEA), whose purpose is to provide the necessary tools for the development of socially and environmentally responsible banks and financial structures.

2

CONTEXT OF THE STUDY

This paper will present an overview of sustainable investment opportunities in the energy sector which are available to local authorities, providing them with all necessary information for an informed choice that meets their specific needs on the best terms available and, at the same time, enables them to achieve both the project objectives and those of the European Union in the field of environmental protection and sustainable development.

The selected instruments take into account the results obtained from a questionnaire on the financial needs of local project partners. This survey was held in Brussels in March 2010 among project partners.

It included six questions, concerning the forms of investment made, the policies adopted and the resources used in the field of sustainable energy. It was aimed at identifying either the strengths or the needs of the partners. The main conclusions that emerged are listed below.

As regards the partners' strengths, it was found out that:

- there is a general, remarkable commitment of resources and efforts for a sustainable development of the communities;
- there is a wide range of different relationships and situations concerning partnerships with third parties coordinated by the local government. It is noteworthy that, when partnerships exist, the role of private parties is quite limited;
- there is an increasing level of attention and actions implemented in the field of private housing (PV installation, energy efficiency, ...), compared with a lower attention given to the industry and the business sector;
- there are significant efforts to raise awareness among citizens concerning sustainable energy.

As regards the partners' needs, it was found out that:

- there is a general scarcity of public financial resources, due to the high level of

public debt and the current economic crisis, and stringent constraints to overcome in order to adequately fund the projects. The banks offer is also not always present and/or proportionate to the specific needs of the public bodies;

- there is a strong desire to put into practise investment projects in collaboration with third parties, in particular with ESCOs, and a consequent need for resources;
- there are some projects to be implemented that contemplate collaboration with the private sector (households, SMEs, investors, funds, ...) and requests of support by lenders;
- there is a widespread shortage of skills and capacity development in local authorities on the topics of projects' assessment and RES.

3

SCREENING OF FINANCIAL OPPORTUNITIES

In this section we will give to the local authorities a short list of investment opportunities in the energy sector by separating the various measures on the basis of the sources of funding.

PUBLIC FUNDS

The first macro-category of analysed tools share the public source of contributions. However, it will be further disaggregated by type of funding agency.

1 - EUROPEAN UNION

While starting this series of initiatives and projects proposed and supported by the European Union, we note that the "European Investment Bank" is deeply committed to supporting sustainable energies. It is the main proponent of two specific initiatives: "**ELENA**" (European Local Energy Assistance) and "**JASPER**" (Joint Assistance to Support Projects in European Regions).

The stable Community Initiative **ELENA** was born within the program "IEE" (Intelligent Energy Europe), and by it financed, to facilitate the mobilization of funds to support investment in sustainable energies by local authorities or groups thereof. In addition to EIB, ELENA was strongly supported by the European Commission and is promoted by the "Covenant of Mayors".

With ELENA Funds, EUR 15 million, up to 90% of the cost of technical advice necessary to prepare, implement and finance an investment program with a total value of 50 million can be covered . They may consist of market research and feasibility studies, action plans structuring, business plans, energy audits, preparation of procedures, contractual obligations, or whatever is needed (excluding overhead costs not directly attributable) to ensure that sustainable energies related projects, implemented by cities and regions, can be developed and are ready to be funded, possibly by the EIB.

Today, in fact, many local authorities have major proposals for energy efficiency and RES, but many of them are blocked at the stage of initiative due to lack of technical capacity to develop them. This difficulty is amplified for small towns and regions.

ELENA helps public bodies to resolve these issues, by offering specific support for the implementation of programs and investment projects, such as efficient renovation of public and private buildings, development of solar energy in public buildings, sustainable constructions, energy-efficient heating and cooling districts and networks, energy efficient and clean urban local infrastructure and transport networks, etc...

Funding for technical assistance must ensure a minimum investment leverage factor¹ of 25 and must not bring any profit to the local government.

Another feature that projects must take is to be replicated: thus a single funding, although local, can produce effects in lots of European cities and regions and can multiply the benefits throughout the Union.

Assistance provided by ELENA may help to facilitate access to funding from the EIB or other financial institutions to finance the project in its phase of implementation.

The program is already active and evaluates applications for funding on the basis of the temporal order of receipt. They should include a description of the investment planned, including its type and the approach adopted for its implementation, the expected cost and the schedule, the purpose and the main needs in terms of technical assistance. Following the assessment of eligibility by the EIB, the institution shall establish a request for assistance which will be subsequently approved by the Commission.

The selection criteria adopted by the EIB regard the eligibility of the applicant and of the investment program, the potential bankability of the program, the financial and technical capacities of the candidate for the implementation and the completion of the project, the expected contribution to the European goals 20-20-20, the leverage factor, the correlation with respect to EU policies, the possible presence of other European instruments best suited to support the

¹ The cost of the investment to be supported must be at least 25 times the amount of the ELENA contribution.

program (unless proven otherwise by the entity itself) and the absence of other forms of EU aid earmarked for the same initiative. The selection criteria regarding technical assistance state that it must be necessary to complete the investment program in line with the principles of sound financial management.

The permanent initiative **JASPER** is exclusively directed to the 12 EU member countries since 2004 (Czech Republic, Cyprus, Estonia, Hungary, Latvia, Lithuania, Malta, Poland, Slovakia and Slovenia) and since 2007 (Bulgaria and Romania); it is managed by the EIB and supported by the European Commission, the EBRD (European Bank for Reconstruction and Development) and KfW (Kreditanstalt für Wiederaufbau - German State Owned Bank).

The main purpose of Jasper is to increase the quantity and quality of projects in different countries, thus enhancing, indirectly, economic growth and employment. Free advice is directed, therefore, to accelerate the absorption of available funds. JASPER therefore assists countries in preparing relevant projects to present to the Structural Funds and the Cohesion Fund for funding, providing both technical assistance during the critical path of the project development, so as to apply to the Call for Expression of Interest for EU funding with high quality applications, and assistance to projects that the EU should co-finance, enabling acquisition of the available funds on time.

The assistance may cover technical, financial and economic aspects and any other preparatory work necessary for the project development, in order to provide advice, develop and review the project structures, remove bottlenecks and solve problems. Examples of assistance include: advice on the conceptual development, project structuring, advice on project preparation (such as cost-benefit analysis, financial analysis, advice on environmental planning and procurement), review of documentation (such as feasibility studies, technical projects and funding applications), advice on compliance with EU legislation (environment, competition, etc..), and compliance with European policies.

The eligible projects are identified and presented to JASPER by the national Managing Authority at the beginning of the year. Later, JASPER analyses and discusses the proposals with the MA and DG Regio, identifying those worthy of

assistance. If the project was selected, after signing an Action Plan, JASPER, the MA and the recipient actively work together. Each member state continues to manage the projects and deals with various Call for Expression of Interest to get funding. The final decision on funding of projects, prepared with the assistance of JASPER, is a responsibility of the European Commission. Similarly, the involvement of JASPER does not create any obligations for funding by the EIB, EBRD and KfW.

The focus of JASPER activities are large projects, costing more than EUR 25 million, in the environmental field (environmental improvement, investment in energy efficiency and RES) and more than 50 million in other areas (networks transport, health, R & D and urban regeneration). These threshold may, however, become flexible in case of smaller countries or where the projects serve as pilot projects to determine best practices.

JASPER operates on the basis of the Action Plan established annually for each country, in collaboration with national authorities, the European Commission and the MA.

The ERDF, "**European Regional Development Fund**" helps to achieve the three goals that the European Regional Policy has set for 2007-2013, which include in the Objective No. 2 on regional competitiveness and employment, also the subject of energy. Thanks to the resources allocated through this fund several notices directed to local government (NUTS 3) have been promoted by various regional authorities of the Union, in order to finance sustainable energy projects.

Each region, through the resources it has been given, structures a notice or a call for expressions of interest, detailing the types of actions eligible and compatible with the regional plans currently in force. The local governments at a lower level, who are interested in receiving funding for projects they implemented and/or operated, can apply with a documented request to the regional body. Usually, the request must include a detailed description of the project, particularly regarding the economic feasibility, its improving environmental impacts and, of course,

timing and costs to be sustained.

Being smaller territorial units than those already discussed, you can also find different ways of selecting the recipients if compared with other institutional levels. E.g., the criterion "first come, first served" is used in many cases, replacing the creation of lists. A previous, careful analysis, however, still takes place: if it ends in a positive assessment of the project, this will be subsequently funded.

The ERDF shall not cover, in any case, the totality of funding: it is therefore expected that a portion of the total cost is engaged by the applicant, either through its own resources or through other forms of funding. There are no obstacles to the possibility of co-financing by the region itself, through other budgetary resources or with resources allocated by other agencies (for example, the central state or linked institutions).

We find, instead, the stable presence of monitoring activities on the use of the funds, requests of reports, deferred contributions and mechanisms of self-defence.

If local authorities adopt specific urban development plans, intervention can also be held through the instrument **JESSICA** (Joint European Support for Sustainable Investments in City Areas), promoted by the EIB and the Development Bank of the Council of Europe (CEB).

JESSICA can collect resources from EU structural funds in order to finance, together with other resources, investment in urban areas through a special Urban Development Fund. By March 2011, EUR 1.65 billion of Structural Funds had already been committed to 19 JESSICA funds in 11 Member States: 15 Holding Funds agreements have been signed with EIB (total EUR 1.49 billion), 1 Holding Fund was set up with a national financial institution (Estonia), 3 Urban Development Funds have been established directly (Brandenburg, East Midlands of England and Wales).

Out of the 19 funds, 7 of them have an energy component, scheduled to invest over EUR 700 million in energy efficiency and renewable energy projects.

The rules governing the basic functioning of JESSICA are the same as the

Structural Funds. The urban development funds in which they are conveyed, however, follow their own rules, although in general terms, we note their ability to produce the so-called "leverage effect". In fact, they usually do not provide grants, but loans or guarantees and partnerships with private entities. Resources may therefore be used repeatedly, thus multiplying the positive effects generated, stimulating other local stakeholders to develop knowledge and skills and attracting investment, especially from the private sector.

IEE, one of three programs in the wider CIP (Competitiveness and Innovation Framework Programme) of the Directorate General for Energy and Transport of the European Commission, in addition to the support offered to ELENA, also funds projects directly, through periodic autonomous **"Call for proposals"**.

In general, at the beginning of every year an announcement is published; it states the opportunity to provide contribution up to 75% of the total project. Both public and private may apply for it, as long as the initiatives are shared by at least three different promoters, established in at least three different countries involved (EU 27 - Iceland - Norway - Liechtenstein - Croatia).

Projects must have clear goals, high impact, credibility and added value at a European level and quality in the implementation processes. The technical and financial capacity of the promoters are also considered. Initiatives cannot be longer than 3 years and the amount of funding usually varies between 0.5 and EUR 2.5 million.

Projects are allowed to funding only if they deal with capacity building, construction and dissemination of know-how, skills and methods, exchange of experience, market development and intelligence, policy input, awareness and information providing, education and training. Structural investment, R & D and experiments or demonstrations are not eligible.

The areas of intervention which are given priority in funding are energy efficiency and rational use of resources (SAVE), new and renewable energy sources (ALTENER), energy in transport (STEER) and integrated initiatives.

The evaluation of the projects starts at the end of the call and an answer is given

usually within the end of the year.

Finally, still within IEE there is also **SEE - Sustainable Energy Europe**, a permanent campaign aimed at increasing public awareness and promoting the production and use of sustainable energy in individuals and organizations, private companies and public authorities, professionals and energy agencies, industry associations and NGOs across Europe.

The specific objectives of the campaign are:

- increasing the awareness of decision makers at a local, regional, national and European level;
- disseminating best practices;
- ensuring a high level of awareness, understanding and public support;
- stimulating the necessary increase of private investments in sustainable energy technologies.

As for local governments and the Thematic Area "Sustainable Communities", the aim of the campaign is to link the numerous entities that, at various levels of government, have already begun to adapt their energy plans towards targets of sustainability, with a combination of legal, regulatory, financial, educational and communication dispositions to promote renewable energies and the management from the demand side. Moreover, while exposing and promoting advanced programs and municipal projects in every field of the production and use of sustainable energy, we aim to make them appreciated and repeated in other European regions. Finally, although local authorities often have to apply to legal and financial instruments, such as public procurement and territorial planning, to support their projects, they are able, thanks to their proximity, to reach consumers and key local actors and to involve them in the common vision of "their" sustainable community.

Surely this is not a financial investment opportunity in the general meaning. However, SEE has proved to be a very useful tool for an administration that is willing to attract the attention of citizens and of the territory on the themes of sustainable energy. This is particularly due to the actions provided by the campaign, such as the "days and weeks of sustainable energy", involving all

stakeholders through exhibitions, workshops, conferences, visits, tests, etc. , and "The Competition Award - Rewarding the best", an annual contest that rewards and publicize the best examples of plans for sustainable energy. Undoubtedly both actions act also as a mean of promotional of all the activities carried out by the institution itself.²

2 - STATE FUNDING

We continue our overview of initiatives and projects funded through public funds, by analysing those proposed and supported by state governments. They often rely on the collaboration of other agencies and related organizations such as state owned banks.

There are three forms of support to public bodies that are generally very similar and widespread across countries.

These are grants, medium-and long-term loans and incentives. Not infrequently we find financial instruments that combine together the first two types of intervention.

The **grants** usually provide an initial notice, given the budgetary allocation of the state, that lays down the rules for applying for funding and the distribution of payments.

Concerned local authorities must provide the required documentation, indicating the type of project to be financed, its technical characteristics, the benefits it brings to the environment and to the local communities who will benefit from it, the the timing of implementation, the estimated cost and the amount of funding requested.

The sponsor of the notice, after analysing the application correctly received before the deadline expires, identifies projects for funding and distributes the funds basing its assessment on the criteria previously established in the notice.³

Funding may also state that the contribution is paid against a project report and,

² This list of EU provided opportunities is, in our opinion, exhaustive with reference the financial tools on sustainable energy available to date.

³ This information is given at a general level and without specific reference. Each country may adopt slightly different procedures for the financial tools established.

possibly, partly in advance at the time of admission to funding. This mechanism grants higher protection to the funder with respect to any misuse of funds. Other protection mechanisms are frequently set in the notices.

Since the financing instruments concern sustainable energies, the money necessary to put in place these types of projects may require significant commitments of resources and, in some cases, they can hardly be fully supported by a government grant.

Therefore, there is the possibility to find "mixed" financial products, which combine a share of grant with a loan.

These types of **loans**, especially if the characteristics of the projects are based on those described above, are therefore often thought in the long run, with amortization schedules that may exceed 20 years of duration, and also with years of pre-amortization, generally equivalent to the time necessary for completing, testing, and initiating the plants or facilities provided.

State owned banks play an important role in providing money to the public authorities.

The amount loaned can reach enormous figures, especially if the established financing instrument requires that the project will be fully funded. Interest rates may vary and are based on the rating of the institution applying for financial support. However, as they are loans made by governments, or by organizations linked with them, to other public bodies, the rates provided are often more favourable than those offered by the market. Local governments are therefore encouraged to use this form of financing to meet their needs.

Again, the parties interested in applying for funding have to set up the necessary documentation to identify the type and characteristics of the project to be financed and the economic feasibility of the operation, in addition to the positive impact on the environment and the local community.

A different type of support to public bodies, but extremely important, is detectable in the implementation of incentive systems for renewable energies production.

Recently it's been experienced a wide use of a **feed-in tariff**, that is a policy mechanism designed to encourage the adoption of renewable energy sources and to help accelerate the move toward grid parity. It typically includes three key provisions:

- guaranteed grid access,
- long-term contracts for the electricity produced,
- purchase prices that are methodologically based on the cost of renewable energy generation and tend towards grid parity.

Under a feed-in tariff, an obligation is imposed on regional or national electric grid utilities to buy renewable electricity and the initial financial burden falls upon the consumer. The cost-based prices therefore enable a diversity of projects (wind, solar, etc.) to be developed, and for investors to obtain a reasonable return on renewable energy investments. In 2008, a detailed analysis by the European Commission concluded that "well-adapted feed-in tariff regimes are generally the most efficient and effective support schemes for promoting renewable electricity", going to grid parity.

3 – REGIONAL AND LOCAL TOOLS

At a lower level of governmental institutions, we see that also Regional Governments are committed to achieving sustainability goals. Indeed, the greater spatial proximity of these citizens and businesses, major users of energy, is directly linked to the involvement and responsibilities that they are invited to bear.

A part from their important role as intermediaries between EU and local beneficiaries(see section "European Union"), Regional Governments usually provide guarantees on loans made by banks. To this end, regional authorities establish special **Guarantee Funds**, which may be used by local authorities that are willing to seek funding on the market to support their projects in sustainable energies. Usually, this warranty is not complete, but covers a share of funding, up to a maximum limit of resources; however it may be combined with other forms of guarantee provided both by private or other public bodies. Mechanisms of protection by the body that provides guarantees are active.

Another particular financing tool, rather typical of local governments, concerns **awards and contests**.

Several regions launch calls that provide to the winners grants; this to recognize successful, especially innovative, relevant and important activities that have been put into practise. The value of these initiatives, however, may be considered in terms of promoting ideas and best practices on sustainable energy instead of in terms of funding opportunities. This tool, however, is useful to spread among the population, companies and other bodies the culture of sustainability. Moreover, the local authority promoting the initiative serves itself as a collector of such tools, centralizing knowledge for a later, possible, distribution.

4 - CREDIT INSTITUTIONS

The first group of institutions are the banks. The main financing tools that are available are basically of three types: loans, anticipations and guarantees.

Many banks include among their financial products, special **LOANS** reserved for local institutions, which provide conditions suitable to their specific needs. They concern the rates, duration, guarantees to be provided and the rates of exposure (often it is a total funding of the investments).

However, these products are not always available, particularly where banks and local governments are facing a substantial delay in the field of sustainable energies. For this reason, the EBRD established the "Municipal Finance Facility", a tool to encourage commercial banks to finance small and medium size local governments. It operates in the 12 countries that joined the EU in 2004 and 2007 and it combines EBRD funds with funds from "Phare", those resources devoted to newly incoming countries and young EU members. Designed financial instruments consist primarily in long-term loans to banks on the same territory, priced according to their credit risk. Then the banks themselves provide financing directly to local authorities. A tool for risk-sharing has also been implemented; it works with the same mechanisms of a guarantee fund, which supports up to 35%

of the funding provided to public entities by the banks. Finally, EBRD provides technical assistance to these banks, by increasing their know-how in terms of services for local governments.

Lenders frequently work in partnership with local authorities, building and developing together projects to be financed through **PROJECT FINANCING** activities.

The use of this tool is much more common as banks are local or particularly related to the territory where they operate.

The banks can provide advice, organization and / or syndication of loans, underwriting and management of funding, warranties and they can play a fiduciary role. They therefore make available their internal resources to contribute to the development of major projects of local governments in terms of maximum efficiency and economy, protecting themselves, at the same time, from the risks which could arise.

Credit institutions shall cooperate with local governments (in particular with the half-private entities linked to them, such as health care companies) also in the role of guarantor, by providing **SECURITY TOOLS**, such as guarantor policies for tenders. Again the conditions are adapted to each particular case.

Finally, another form of financing that is often requested to the banks by local authorities is the **ANTICIPATION**. It can be attached to contributions from higher-level institutions, the European Union or from private entities. If the lending institution is public, the terms offered may be particularly favourable, given the limited risk of the operation to be carried out. The timing of delivery, however, can be rather deferred.

In many cases it is agreed to canalize the contribution to the bank, which therefore further reduces its risk. This happens frequently in case of instalment repayments, such as incentives for solar photovoltaic.

The second category of financing opportunities for a local government is leasing. This is a particularly innovative tool for public administrations, that has been imported from the world of private enterprises after the huge success it has collected.

Through lease tools, local authorities, usually in the guise of tenants, can schedule projects, whose implementation will be through the so-called indirect procurement.

Indeed, the public work is constructed by the leasing company, that at the same rents it, giving the government the right to redeem, at the end of the lease, the work. In other words, with the lease the public body willing to carry out a specific action acquires the property, whose value contributes either directly or instrumentally to the achievement of its targets, without committing all necessary resources to the purchase, but upon payment of a periodic rental.

This financial instrument is used especially for the acquisition of vehicles, but can be adapted for other types of works, such as parks, facilities for renewable energies, infrastructure, etc..

6 - THIRD PARTY FINANCING

The third option available on the market for a public body is the third party financing. It generally consists of establishing and using services offered by ESCOs and Energy Consortia.

A local authority may give rise to an **ENERGY SERVICE COMPANY** (ESCO) to involve the community towards achieving certain goals in the energy field, but at the same time outsourcing these activities. Thus, the public body, while maintaining a form of control, is relieved from duties relating to the implementation of projects, and acting through private companies is not bound by operational constraints and budgetary legislation imposes.

The ESCO may be initially financed both through the placement of its capital among the public or through the capital markets. Proceeding in its business, it will manage to sustain itself through the revenues that production and sale of energy generate.

The typical activities that an ESCOs carries out are the production of energy, with a widespread, particular focus on energy efficiency and renewable energies, and the provision of the same on the local and national market. Frequently, the ESCO can take the ownership and/or the control of production facilities, which may be designed, built and developed by the ESCO itself. It should be noted, therefore, the high concentration of know-how that, ultimately, is part of a public body, which may make it freely available, expendable and replicable.

Also, thanks to the mix of private and public resources available, it may be possible to carry out successful R & D investments.

The second possibility for a local authority is to create an **ENERGY CONSORTIUM**. The institution creates, along with other public bodies or their subsidiaries, alliances, which have a renewable energies promoting function in the territory, a lobbying function and the duty of implementing campaigns for energy conservation and judicious and intelligent use of the natural resources through which energy is produced.

The consortium may also constitute a sort of collective purchasing group between local government authorities, which allows considerable savings of time and money in the energy supply securing.

7 - SHARED OWNERSHIP

An additional means of intervention available to the public entity is the use of the citizens' resources through the implementation of projects of shared ownership.

The public body usually schedules the construction of a plant for the production of renewable energies and sets up a purpose company in which citizens and local businesses can become members. Otherwise the ownership of the facility can be divided into shares, thus creating as a multi-property facility.

The investment can be repaid by specific energy grants or by the revenues generated from the sale of the energy produced, in addition to the institution's savings on the energy bills. The profits are periodically redistributed to the investors, as per the contract of subscription of shares or of the share of

ownership.

If there are government grants to support the production of energy from renewable sources, the investment has low risk margins and a return at least adequate; it proves to be, therefore, particularly attractive to citizens.

8 - PRIVATE INITIATIVES COORDINATED BY PUBLIC BODIES

The last available option to local authorities to achieve environmental sustainability objectives is promoting investment and private initiatives, coordinated by the public body, but implemented by individual actors.

4

COST/BENEFIT ANALYSIS

1 - EUROPEAN UNION

ELENA - European Local ENergy Assistance

STRENGTHS

- Partnership with the "Covenant of Mayors"
- Up to 90% of the cost of technical advice covered
- Easy access to EIB financing

WEAKNESSES

- Only for large projects (minimum investment leverage is 25)
- "First come first served" criterion for financing⁴
- Application assessment based on technical features for a positive completion of the project (presence of specific skills in the local government employees is assumed)

OPPORTUNITIES

- Replicable of the projects
- Supply of technical capacity for project development

THREATS

- Absence of direct funding for the project realization
- Interdiction to use other forms of EU aids for the same initiative

JASPER - Joint Assistance to Support Projects in European Regions

STRENGTHS

- Specific attention to new EU countries
- Combined ex-ante and ex-post technical assistance for project implementation
- Possibility of co-funding

WEAKNESSES

- Absence of attention for less developed areas of other EU member countries
- Screening conducted by a national Managing Authority at the beginning of the year
- Only large projects, costing more than 25 or 50 million Euro, depending on the purpose, except for experimentations

OPPORTUNITIES

- Possibility of access to different form and sources of funding

THREATS

- Absence of direct funding for the project implementation
- Subordination to single countries

⁴ If compared to a notice with a following list of the projects to be financed, this criterion may be considered either as a strength or as a weakness. It may be a strength because a longer period to apply for funding is available. Though that, a higher quality level of the project must be required in the call for expression of interest, in order to exclude from funding first come but lower quality level projects. This implies for the LG a further evaluation to be carried out.

- Technical capacity to annual Action Plans develop project is supplied

ERDF - European Regional Development Fund

STRENGTHS

- Direct link EU - territory
- Large amount of available resources

WEAKNESSES

- "First come first served" principle
- Impossibility of total funding and co-financing solutions non provided

OPPORTUNITIES

- Support to important projects at a local level

THREATS

- Absence of technical assistance
- Need to comply with current local regional plans

JESSICA - Joint European Support for Sustainable Investments in City Areas

STRENGTHS

- Large amount of available resources, coordinated and provided by different funds
- Flexibility in the management of the Urban Development Funds, where all the resources are joint

WEAKNESSES

- Limited to those territories already provided with Urban Development Plans
- No contribution but only loans or guarantees

OPPORTUNITIES

- Capacity of resources attraction, leverage and coordination

THREATS

- Available almost only for large cities

IEE "Call for proposals"

STRENGTHS

- Possibility of partnership with privates
- - Up to 75% of the total costs (not only of the cost of technical advice) can be funded

WEAKNESSES

- Participation of at least 3 different promoters from at least 3 different beneficiary countries
- Maximum 3 years long projects

OPPORTUNITIES

- Creation of added value at

THREATS

- Impossibility to fund structural

- a European level
- More than one opportunity along time, thanks to repeated calls for expression of interest
- investments
- Different priorities for each call

SEE - Sustainable Energy Europe

STRENGTHS

- Partnership with the "Covenant of Mayors"
- Public opinion involvement and promotion to the use of sustainable energy

WEAKNESSES

- Net separation between different themes and respective partners involved
- Absence of partnerships between different subjects and territories

OPPORTUNITIES

- Exchange of best practices
- Widespread cultural lobbying action

THREATS

- Absence of direct funding to the initiatives

2 - STATE FUNDING

GRANTS

STRENGTHS

- Direct funding
- In general, no "First come, first served" principle

WEAKNESSES

- Reduced share of co-financing
- Not provided co-financing solutions

OPPORTUNITIES

- Support to important projects at a national level

THREATS

- Scarcity of state resources
- Absence of technical assistance

LOANS

STRENGTHS

- Long time amortization schedules
- Possibility of grace during the project implementation phase
- Particularly favourable loan terms

WEAKNESSES

- Reduced funding share
- Not provided co-financing solutions

OPPORTUNITIES

- Support to important projects at a national level

THREATS

- Scarcity of state resources
- Absence of technical assistance

FEED-IN TARIFF

STRENGTHS

- Burden is usually on final consumer and not on public body

WEAKNESSES

- Uncertainty of a determination of incentives

OPPORTUNITIES

- Adaptability of mechanism towards grid parity

THREATS

- Risk of price distortion

3 – REGIONAL AND LOCAL TOOLS

GUARANTEE FUNDS

STRENGTHS

- Guarantees can be used jointly

WEAKNESSES

- Only partial guarantees

OPPORTUNITIES

- Public support to private credit lending

THREATS

- Support but not incentives to the launch of new projects

AWARDS AND CONTESTS

STRENGTHS

- Contribution provided, even if reduced
- Promotional function for initiatives held

WEAKNESSES

- Ex-post contribution, not on a project basis

OPPORTUNITIES

- Exchange and distribution of best practices
- Local cultural lobbying action

THREATS

- Absence of direct funding for the initiatives

4 - CREDIT INSTITUTIONS

LOANS

STRENGTHS

- Special and favourable conditions
- Possibility of total funding for projects
- Large availability of resources

WEAKNESSES

- Need for guarantees

OPPORTUNITIES

- Possibility to access resources and guarantees made available through the "Municipal Finance Facility" for the 12 new UE members

THREATS

- Absence of coordination between local governments and their projects
- Credit institutions lobbying

PROJECT FINANCING

STRENGTHS

- Technical assistance available
- Cost savings on the project implementation

WEAKNESSES

- Outsourcing of key functions
- Risk of non use of local government resources, if present

OPPORTUNITIES

- Possibility to develop projects with relevant expenditure commitment

THREATS

- Low level of control for the local government

ANTICIPATION

STRENGTHS

- Special and favourable conditions, as there is a low risk

WEAKNESSES

- Increase of costs in case of delays in the contribution providing

OPPORTUNITIES

- Availability of a consistent amount of financial resources without depending on contribution providing schedules

THREATS

- Support but not incentives to the launch of new projects

SECURITY TOOLS

STRENGTHS

- Special and favourable conditions

OPPORTUNITIES

- Facilitation to access other forms of contribution, in particular from public sources

WEAKNESSES

- Need to pay this service

THREATS

- Support but not incentives to the launch of new projects

5 – LEASING

LEASING

STRENGTHS

- Costs and financial commitments reduction
- Payments spread along time

OPPORTUNITIES

- Incentive to investments, especially for those particularly relevant

WEAKNESSES

- Possible contract constraints
- Presence of a starting charge
- In case of long time operations, the increase of costs could be higher than the financial costs linked to a possible purchase

THREATS

- Scarcity of control, due to the absence of property rights

6 - THIRD PARTY FINANCING

ESCO - Energy Service COmpany

STRENGTHS

- Control on the company is maintained
- Less duties for the public body
- Absence of budget and operational constraints that laws state for local governments

OPPORTUNITIES

- Self-financing of the local government through the ESCO's income flows
- Concentration in the local

WEAKNESSES

- Large amount of resources to be found on capital markets
- Need of previous specific knowledge in the local government

THREATS

- Indirect enterprise risk assumption for the local government

government of replicable know-how

ENERGY CONSORTIA

STRENGTHS

- Cost savings
- Local partnerships

OPPORTUNITIES

- Absence of direct risk
- Lobbying e promotion of RES on the territory

WEAKNESSES

- Resources commitment to build and manage the consortium

THREATS

- Stability of the agreement along time and different government mandates

7 - SHARED OWNERSHIP

SHARED OWNERSHIP

STRENGTHS

- Direct and autonomous management of the project
- Local community involvement

OPPORTUNITIES

- Promotion of RES on the territory

WEAKNESSES

- Periodical need to repay the investment to be linked to the budget constraints

THREATS

- Financial sustainability of the project along time

8 - PRIVATE INITIATIVES COORDINATED BY PUBLIC BODIES

STRENGTHS

- Cooperation between private and public
- Easy at local level

OPPORTUNITIES

- Networking among different partners can generate new opportunities and projects

WEAKNESSES

- Public funds are generally low
- Difficult at national level
- Difficult coordination when many actors

THREATS

5

BEST PRACTICES

1 - EUROPEAN UNION

<p>ELENA European Local ENergy Assistance <i>“Province of Barcelona”</i></p>	<p><u>Project promoter:</u> Province of Barcelona - Spain http://www.diba.cat/mediambient/Pactealc.asp <u>Duration:</u> 2010 – 2012 <u>Contribution received:</u> EUR 2.000.000,00</p>
---	---

Funding to finance the necessary technical assistance for the development of a EUR 500 million investment programme. This programme is expected to lead to 87.5 MWp of photovoltaic (PV) installed capacity with a potential electrical capacity of 114 GWh per year. From a social point of view, 4.500 new jobs will be created as a result of the investment programme.

The funding potentially created through the ELENA facility will help Barcelona execute the 56 activities outlined under the energy plan. These environmental measures cover the areas of sustainable transport, waste management, sustainable building and energy efficiency.

To date, more than 100 towns and cities in the Province of Barcelona have signed-up to the Covenant of Mayors. Each signatory is committed to adopting the necessary environmental measures to help them fight climate change.

Through the help of the ELENA facility and the Covenant of Mayors, the Province of Barcelona can encourage the region’s other towns and cities to adopt similar environmental measures.

The vital financial and technical assistance provided by the ELENA facility will go a long way to ensuring local authorities can deliver their sustainable development programmes. By providing them with the tools to meet the challenges of climate change, the EU can help local actors develop their own grassroots solutions.

<p>JASPER - Joint Assistance to Support Projects in European Regions</p>	<p><u>Project promoter:</u> City of Burgas- Bulgaria <u>Duration:</u> February 2009 - June 2009 Approx. Value of Services received by City of Burgas:</p>
--	---

“Burgas Integrated Urban Transport Project ”	EUR 130.000,00
---	----------------

The objective of the project was to upgrade the transit system in Burgas:

- Develop faster transit network with the establishment of new BRT (Bus Rapid Transit) route.
- Increase attractiveness through improved accessibility.
- Greater mobility for the community and visitors of Burgas.
- Priority to environment friendly modes of passenger transport: BRT line, upgraded transit system, bicycle and walk modes.
- Environmental improvement through reduced emissions, developing alternative for the old trolleybus systems and/or buses presenting low levels of pollution.

ERDF - European Regional Development Fund BANDO POR FESR 2007-2013 ASSE III	<u>Project Promoter:</u> Regione Toscana - Italy http://www.regione.toscana.it <u>Duration:</u> various calls for expression of interest <u>Project beneficiaries:</u> SMEs, companies, consortia, local governments
---	---

Physical investment in the field of renewable energies, energy efficiency, co-generation and district heating. Particularly actions to reduce the energy used, especially in the production cycle.

Interventions are aimed at increasing energy efficiency at a regional level and to promote efficient energy management systems, with the aim to increase competitiveness in the markets. In particular, measures related to saving, reduction and stabilization of the growth of energy consumption and rationalization of the end-use of the public administration.

JESSICA - Joint European Support for Sustainable Investments in City Areas “Muenchen Stadtentwaesserung“	<u>Project Promoter:</u> Münchener Stadtentwässerung – Germany http://www.muenchen.de/mse <u>Proposed EIB finance:</u> € 100 million <u>Total cost:</u> € 200 million
--	---

The operation concerns investments into Munich’s waste-water collection and treatment infrastructure and will complement funding of the 2009 –

2012 investment programme. The main components of the investment programme concern the continuous rehabilitation and extension of the canalisation system as well as the upgrading of the Waste-water Treatment Plants to meet modern performance criteria and requirements of national and EU legislation.

The project will result in measurable benefits of the quality of receiving water bodies. The investment programme aims to ensure compliance with tighter environmental and customer service standards set by EU and national legislation. The compliance of the programme with EU environmental legislation will be assessed during appraisal.

<p>JESSICA - Joint European Support for Sustainable Investments in City Areas “Lithuania Holding Fund“</p>	<p><u>Project Promoter:</u> Ministry of Finance & the Ministry of Environment of Lithuania - Lithuania <u>Total funds:</u> € 227 million</p>
---	--

The Fund was established in June of 2009 and is managed by the EIB. Possible financed projects must deal with energy efficiency investments in multi-apartment buildings.

Lithuanian National Plans forecast to refurbish 24,000 apartment block buildings by 2020, with an average estimated energy saving for a single building of 50 %. JESSICA target is to fund renovation investments for 1000 buildings between 2010 and 2015. To date, about 100 projects have been approved for funding by the Housing and Urban Development Agency (“HUDA”).

Loan agreements will be signed between the EIB, as manager of the JESSICA holding fund in Lithuania, the “Šiaulių bank” and “Swedbank”. Both banks will provide modernisation loans for energy efficiency for a total amount of € 12 million to individual apartment owners. Loans can have a maturity up to 20 years and are given at a fixed interest rate of 3%; no loan insurance or third party guarantee are required. Bank may require a down payment (not more than 5%)

Key elements of State support are the following:

- 100% grant for feasibility studies of projects
- 15% loan rebate where minimum energy efficiency level is met
- Exceptional 100% subsidy on loan repayments for low-income persons

Future plans for renovation projects to be undertaken are student dormitories (classified as housing in Lithuania).

<p>JESSICA - Joint European Support for Sustainable Investments in City Areas “Spanish FIDAE Fund”</p>	<p><u>Project Promoter:</u> The European Investment Bank (EIB) and the Spanish Energy Saving and Diversification Institute (IDAE) – Spain <u>Total funds:</u> € 127 million</p>
---	---

Energy efficiency, renewable energy and clean transport projects in the construction, industry, transport and energy-related public service infrastructure sectors will be eligible for financing by this facility. The capital contributions of FIDAE (the Energy Saving and Diversification Investment Fund) will come from the 2007-2013 ERDF Regional Operational Programmes for Andalusia, the Canaries, Castilla y León, Castilla-La Mancha, Ceuta, the Valencia Region, Extremadura, Galicia, Melilla and the Murcia Region, where the investments will be made. Of that amount, EUR 87.8 million will come from the EU’s European Regional Development Fund (ERDF).

The fund will also be designed to leverage private finance to achieve a total investment target of up to EUR 600 million by the end of December 2015. The available resources will be channelled through urban development funds managed by financial entities that will act as intermediaries selected by competitive tendering once the fund has been launched. The financial products to be deployed will take the form of mainly loans but also venture capital and participating loans.

<p>JESSICA - Joint European Support for Sustainable Investments in City Areas „<i>London JESSICA Fund</i>“</p>	<p><u>Project Promoter:</u> European Regional Development Fund, London Development Agency, London Waste and Recycling Board- United Kingdom</p> <p><u>Total funds:</u> £ 100 million (£ 50 million from the European Regional Development Fund, £ 32 million from the London Development Agency and £ 18 million from the London Waste and Recycling Board)</p>
--	---

Financed projects are decentralised energy infrastructure with more efficient electricity and heat production located closer to the consumer (reducing transmission loss); waste infrastructure can be financed too when they present increased recycling capacity or reduction of landfill. Project funding will be concentrated in regeneration areas with substantial deprivation.

<p>Intelligent Energy Europe</p> <p><i>Demonstration, take-up and further dissemination of sustainable integrated planning methods in European cities (SNOWBALL)</i></p>	<p><u>Project promoters:</u> Cities (among them Ludwigsburg - Germany), private companies, universities, analysts groups.</p> <p>http://www.steer-snowball.info</p> <p><u>Key action:</u> Energy-efficient transport</p> <p><u>Benefits:</u> Integrated urban planning methods implemented in cities, knowledge and skills embedded in cities' organizations, reduction of private transportation and energy consumption</p> <p><u>Duration:</u> 01/01/2006 – 31/12/2008</p> <p><u>Budget:</u> EUR 1.508.238,00 (EU contribution: 50%)</p>
---	---

Results:

- The anchoring of integrated-approach thinking in 5 cities: S. Sebastian-Donostia, S. Fernando de Henares, Ludwigsburg, Zvolen, Martin.
- Integrated urban plans in 5 cities.
- National quality support groups (expert networks) on integrated planning in 5 countries (DE, ES, NL, PL, SK).
- A web based tool-kit of integrated planning methods and best practices.
- 26 new cities interested in the implementation of the Snowball concept.

Lessons learnt:

- Importance of involving local politicians, decision makers and key stakeholders early in the process. The time-frame of the project also needs to match key political milestones.
- Importance of developing a sound and comprehensive baseline analysis of the city potentials and challenges at the start of the project.
- Communication means should be used extensively and creative ways of addressing the target groups can lead to wide successes.

<p>SEE - Sustainable Energy Europe</p> <p>100% green power for Munich by 2025</p>	<p><u>Project Promoter:</u> Stadtwerke München GmbH - Germany (SWM), Germany http://www.swm.de/en</p> <p><u>Duration:</u> 01/2009 - 12/2025</p> <p><u>Campaigning area:</u> Sustainable energy communities</p> <p><u>Project beneficiaries:</u> beneficiaries will be both industrial and private consumers of electricity.</p>
--	--

By 2015 SWM is to generate an amount of green power equivalent to the demand of all private households in Munich. And by 2025, SWM wants to produce as much green power as to cover the total power requirement of Munich.

In order to achieve its ambitious targets, SWM has started an expansion campaign for renewable energies.

SWM only invests in business projects which are financially self-supporting. It estimates an investment volume of around 9 billion Euro by 2025.

2 - STATE FUNDING

<p>Grants</p> <p>"Il sole negli Enti Pubblici"</p>	<p><u>Project Promoter:</u> Ministry for the environment - Italy http://www.minambiente.it</p> <p><u>Duration:</u> various calls for expression of interest</p> <p><u>Project beneficiaries:</u> Italian local governments</p>
---	--

The Italian Environment Ministry allocates funds to finance solar thermal systems for the production of low temperature heat on public buildings. These ones may apply to the Ministry, as per the predefined criteria of the

notice, to obtain funding for the facility.

Loans KFW Renewable Energies Programme	<u>Project Promoter:</u> KFW Mittelstandsbank - Germany http://www.kfw.de <u>Duration:</u> stable tools <u>Project beneficiaries:</u> private citizens, SMEs, public bodies for investments only in Germany
--	--

Long-term, low-interest loans with several grace years for investments in RES. The amounts vary depending on the type of investment. Up to 100% of the eligible net investment costs (without value-added tax) can be funded, with a maximum of €10 million. Particularly significant projects receive special interest rates and support.

Incentives “Conto Energia” Italian Feed-in tariff	<u>Project promoter:</u> Ministry of Economic Development – Italy http://www.gse.it <u>Duration:</u> until the reach of 23 GWp installed <u>Project beneficiaries:</u> Private citizens, SMEs, public bodies
---	---

Since 2005 Italy has a feed-in tariff system to sustain investments in PV systems connected to the grid. On 06/05/11 the National Government has adjusted the amount and the characteristics of the State support. The tariffs vary according to the level of building integration (the highest for total integration, the lowest for no integration) and to the power of the system (the highest for low power plants, the lowest for large plants). The tariff is constant over 20 years and is proportional to the energy produced by the PV system. PV plants on public buildings are always considered as “totally integrated”.

3 – REGIONAL AND LOCAL TOOLS

Guarantee Funds Fondo Regionale di Garanzia per gli investimenti delle Piccole e Medie Imprese	<u>Project Promoter:</u> Regione Toscana - Italy http://www.regione.toscana.it <u>Duration:</u> stable tools <u>Project beneficiaries:</u> SMEs, public bodies, associations, private citizens
--	---

The Italian Region has established a guarantee fund to assist SMEs seeking funding to banks. Eligible investments cover a variety of areas, including projects in the energy sector. Stakeholders may apply for admission to guarantee following the rules established by the regional law.

Awards and contests Premio "Toscana Ecoefficiente"	<u>Project Promoter:</u> Regione Toscana - Italy http://www.regione.toscana.it <u>Duration:</u> annual award <u>Project beneficiaries:</u> either public or private subjects
--	---

The contest is held in Tuscany. The invitation is to report actions and good environmental practices implemented by those who have actually innovated processes, systems, technologies and products in a perspective of eco-efficiency, sustainable development, respecting of ethical and social issues, sustainability and quality of life.

4 – FINANCIAL INSTITUTIONS

Loans	<u>Issuer:</u> Banca Popolare Etica scpa - Italy http://www.bancaetica.com
-------	---

Banca Popolare Etica cooperates with Local Governments to fully finance energy projects (up to € 5 MLN). The Bank can help the public body by:

- evaluating the business plans,
- constructing the covenants and security package,
- writing the financial contract.

Project Financing	<u>Issuer:</u> Banca Monte Paschi Siena-Italy http://www.mpscapitalservices.it
-------------------	--

MPS Capital Services assists the promoters for the financial aspects of their project, fulfilling the following roles:

- Advisor (consulting on feasibility, based on project financing)

- Arranger (advice on bankability of the project and on its syndication)
- Lender, both individually and as part of a pooled funding.

Within these activities, the Bank can assist the promoters:

- for the preparation of financial business plans,
- to define the optimum mix of funding sources (both ordinary and facilitated, both debt and equity based)
- for the setting and adaptation of the project eligibility condition, by defining the traditional and contractual collateral package,
- by providing direct and / or seeking the necessary funding.

5 - LEASING

Leasing	<u>Issuer:</u> Banca Monte Paschi Siena – Italy http://www.mpscommercialeleasing.it
---------	--

MPS Commerciale Leasing provides local governments with all the leasing services it has available⁵ for companies and private bodies.

Local governments can take advantage from MPS wide experience and range of leasing products and, therefore, benefit from their features (e.g. certainty of costs to afford and project time sheet, insurance, reduced commitment of resources, etc.).

6 - THIRD PARTY FINANCING

Thameswey Energy	<u>Project Promoter:</u> Woking Borough Council – United Kingdom http://www.thamesweyenergy.co.uk
-------------------------	---

The development of local integrated sustainable and renewable energy solutions was facilitated through the creation of Woking Borough Council's wholly owned energy and environmental services company (ESCO), Thameswey Group. Its purpose is to enter into public/private joint ventures to deliver its energy and environmental strategies and targets (primarily energy, tackling fuel poverty, waste, water and green transport). The

⁵ - in the Italian law there is no difference between private and public bodies concerning leasing contracts.

company has allowed the council to capitalise on its intellectual property in small-scale CHP to enable large-scale district CHP to be implemented, primarily with private finance.

The use of the Thamesway Joint Venture Projects has allowed the council to escape capital controls that would be imposed on a purely local government venture.

Woking Borough Council has utilised cross-sector partnership effectively to gain the finances and expertise required to put sustainable energy innovation into practice.

The use of Thamesway as a separate venture allows knowledge and expertise to be shared and projects replicated outside of Woking Borough.

In Woking's case, Thamesway is wholly owned by Woking Borough Council. Each project progressed by the ESCO is based on a twenty to thirty year project business plan with an internal rate of return of circa 8%. The economics of a project rely upon being a generator, distributor and supplier of energy with retail sales income (plus renewable energy credits where applicable) being critical to financing projects. Energy prices are tracked to give affordable "market comparable" charges to businesses and 5% below a basket of major energy company dual fuel tariffs to residential customers. In May 2000, the company financed the installation of the Combined Heat and Power (CHP) energy station in Woking Town Centre. The 1.3MW energy station supplies electricity, by private wire, and heat and cold water services by pipe to both public structures (office, conference centre, museums car park) and private buildings (hotel, nightclub). In addition, electricity is supplied to other Woking Borough Council sites, including residential properties, by the public electricity network. Further case studies are available at

<http://www.woking.gov.uk/environment/climate/Greeninitiatives/sustainablewoking>

Energy Consortia Consorzio Energia Toscana	Promoters: Local governments at different levels, Universities, Consortia – Tuscany Region – Italy http://www.consorzioenergiatoscana.it
--	---

The main objectives of the consortium are to purchase the energy needed to meet the needs of the member companies on the best terms available on the national and/or foreign market, to reduce the energy consumption of the partners, to provide technical assistance and advice to members in matters related to the corporate objectives and to provide integrated services for the implementation and the possible following management of interventions to reduce consumption of primary energy in the development and utilization of renewable sources.

7 - SHARED OWNERSHIP

Shared Ownership “Fotovoltaico Partecipato”	Promoter: Comune di Vicchio – Firenze – Italy
---	---

Pilot example in Italy, it was born as the first form of direct citizen participation in public affairs, giving the possibility, given a small financial and a great social commitment, to have a personal indirect return through the savings of the municipality, an increase in services and/or a further improvement in energy efficiency of municipal buildings, resulting in savings from other savings and creating a real virtuous circle.

The initiative, started by a group of citizens, proposes to join to other citizens to build a photovoltaic system over the roof of the elementary school, allowing participants, thanks to the state energy incentives, to obtain an economic return of 4% for 20 years committing a minimum of € 1,000 shares to a maximum of € 10,000, and allowing the City to save on electricity bills € 7,200 per year, with an investment of zero.

8 - PRIVATE INITIATIVES COORDINATED BY PUBLIC BODIES

Private Initiatives coordinated by public bodies "Padova Solare"	<u>Promoter:</u> Comune di Padova - Italy http://www.padovanet.it <u>Duration:</u> July 2010 – December 2010
--	--

The main objective is the cooperation between the Padova PV District (3 main PV producers are based in Padova), Padova Municipality and Financial Institutions in order to give Padova citizens the opportunity to have a PV system installed and financed. The agreement between the actors states that the Municipality coordinates the contacts with citizens and the communication campaign and activation of an help desk. The 3 PV companies give a free estimate of costs and a home survey, while financial institutions create a low interest financial product.

6

VALUE FOR MONEY ASSESSMENT

There are many aspects to consider when planning and implementing sustainable energy actions from a financial point of view. In the next page the image shows how financing tools for LG are related to the main selection criteria to be adopted. This should help to reach to the optimal choice of the financial instrument (or mix), considering the constraints and available opportunities.

In case we need to finance the project development and planning three European instruments are available: ELENA and IEE for all countries and JASPER for the 12 EU newcomers. However, these instruments present special features and stringent constraints, and so they cannot cover all possible needs of LG.

In case we need to implement the project, the possibilities are more numerous and may be offered also at private level. Nevertheless, it's necessary to define some project features in order to choose the right financial tool. Briefly, a Local government should analyse the Legislative Framework at European / National / Regional levels and define the projects' amount of investment and Business Plan.

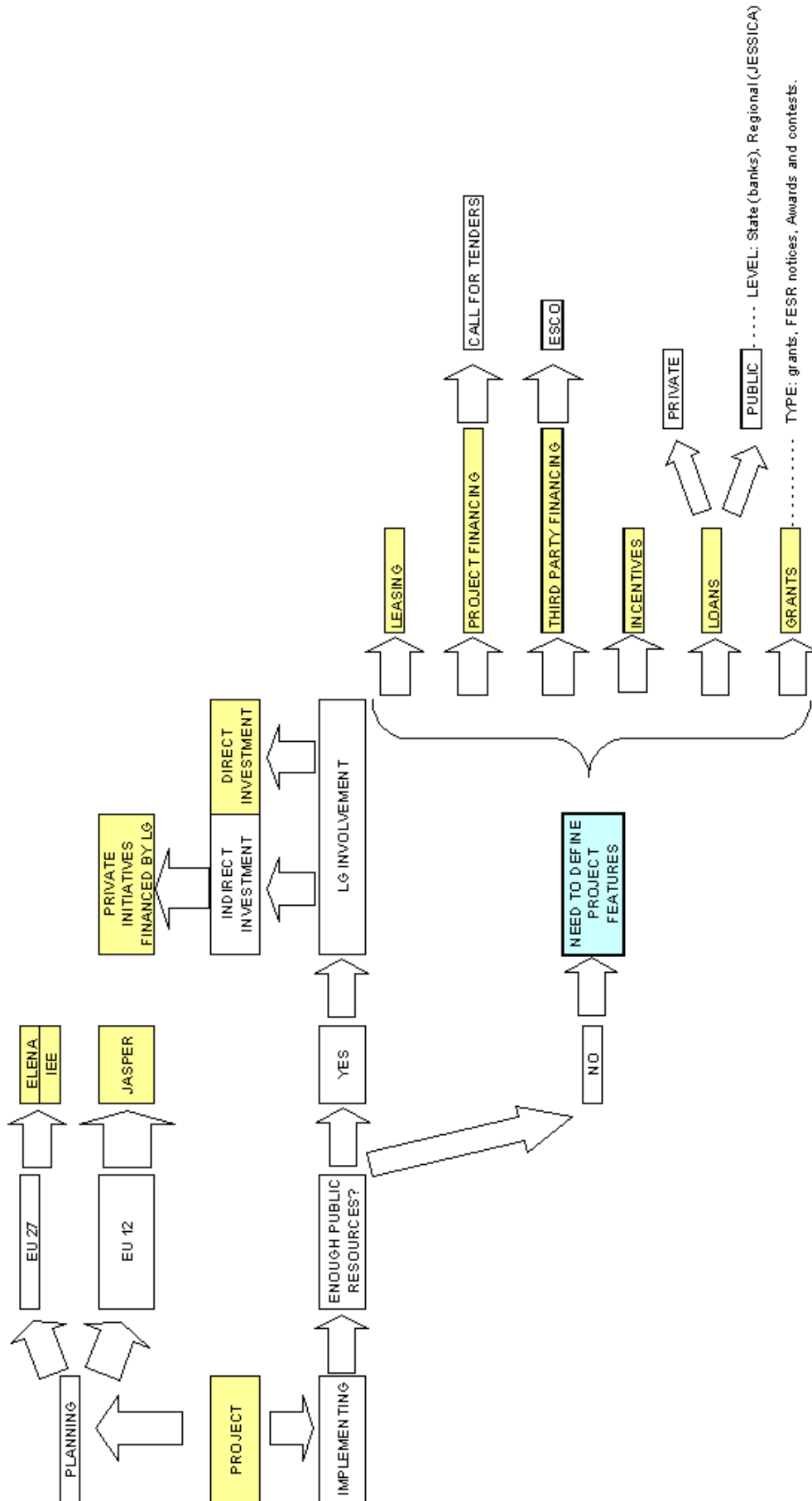

7

FINANCIAL PLANNING OF PROJECTS

In this section some examples on how you evaluate project in order to win the financial feasibility will be presented.

The “Solar Padova” project.

"Padova Solar" is a project proposed by the City of Padua to facilitate the installation of photovoltaic systems by its citizens. The Environmental Department of the City Council has identified three groups of stakeholders to be contacted to develop the project:

- The *City of Padua*, because one of its goals is to achieve a remarkable diffusion of Sustainable Energy plants in compliance with the Kyoto Protocol and the “20/20/20” objectives of the European Union. The City of Padova is also the best way to get in contact with citizenship.
- The *PV panels producers*, since they are players that can ensure the reliability of the product, the know-how and experience to provide a quality service for the installation and maintenance of plants. In addition, in Padua there is the largest district of Italian PV panels manufacturers: they are also interested in promoting their business on local territory.
- The *local banking institutions*, because they can provide access to credit, necessary to cover part or all of the investment required to install the equipment.

During spring 2010, there have been numerous meetings between the City, the PV panels producers and some banks. The main points under discussion eventually led to the definition of the main aspects of the project:

- An Help Desk was opened, managed and financially covered by the City of Padua. The desk operates a daily relationship with citizens and has a toll-free number and is intended to be the “first contact” for citizens.
- A complete package of installation is supplied by the PV panels

manufacturers: certified installers are alerted by the Help Desk and come out for a free visit and leave a data sheet. The producers also ensure a complete solar installation with their panels, a favourable price and maintenance included for the first 3 years.

- A financial package that allows the citizen to fully cover the cost of the photovoltaic system is supplied by financial institutions. Financial products are designed to match the charge of the loan with the state credit given for PV systems. The financing process is fast since it is sufficient that the citizen enters the bank with the data sheet given by the installer and some documents regarding his/her wage in order to access to credit.

The agreement was signed in June 2010 and is valid until the end of 2010.

Signatories to the Agreement are the following:

- City of Padua,
- PV panels manufacturers (XGroup Spa, Spa Solon, Helios Technology – Kerself Group),
- Banks (Banca Popolare Etica, Credit Cooperative of St. Helena, Cassa di Risparmio del Veneto, Banca Antonveneta, Banca Veneto).

The "Solar Padova" Agreement can be found on the website of the City of Padua:

<http://www.padovanet.it>

Joint PV Project in Coriano (RN)

The project sees the financial support of Banca Etica in favour of Esco (Innesco SpA) for the construction of a PV plant on the property of the City of Coriano (Province of Rimini, center of Italy).

The Municipality has issued a Call for Tender for the use of some building roofs, offering the possibility for private actors to exploit it through a PV plant and by paying the City a surface right.

The operation has seen the involvement of different actors:

- *Social Romagnolo Consortium*: it's a consortium of social co-operatives of Rimini that has played a significant role in the application to the Call. It has also been involved in the construction of the plants themselves, and in the O&M as well;
- *UBISOL s.r.l.*: it's a company specializing in plant designing and constructing, responsible for the plant planning and supervision of construction;
- *Innesco s.p.a.*: it's an Esco, whose shares are owned by Banca Etica, who owns the plants and took care of the financial issues and is managing the economic and financial cash flows from operations, both during the erection and working of the plant;
- *City of Coriano*: it's a local public administration who has accepted a project proposal presented by the Consortium and published a Call for Tenders. The Municipality has made the surface available for investors for a period of time long enough to pay back the investment;
- *Banca Popolare Etica*: it's a bank that has financed the construction of the plants with an unsecured loan for a period of 20 years including 12 months grace period. The amount of the loan was equal to 100% of the value of investment.

Banca Etica gave credit to Innesco SpA as responsible of the plants and of the economic and financial flows of the project. In particular, the revenues that will ensure the return of the investment will be secured by the sale of electricity and the public incentive called "Conto Energia". The bank has made an assessment taking into account both economic and legal aspects and considered the presence of social aspects positively.

In the credit assessment, the documents provided by Innesco Spa on business planning have been carefully evaluated. Particular attention has been placed to main financial indicators such as the Debt Service Cover Ratio (DSCR) and the Internal Rate of Return (IRR) of the investment. Both indicators have been stressed to worst-

case conditions

From an administrative point of view, the bank has paid attention to the elements characterizing the contract between the City and the “ATI” (Temporary Association of Enterprises), formed by Innesco, CSR Consortium and UBISOL. It was requested that the time length of the All Risks insurance cover could be equal to the contract between the parties, together with a bond in favour of the bank.

Moreover, the correctness of the completion of various construction permits and administrative have been analysed.

If we look at the social added value of the project, it was clear that for Banca Etica the operation was particularly interesting for two reasons:

1. construction of plants to replace roofs filled with asbestos;
2. involvement of social enterprises for the construction and management of the plants will lead to job opportunities for disadvantaged workers.

Plant data

- 3 PV systems peak powers: 41.4 kWp + 29 kWp + 52.4 kWp
 - “MAGAZZINO-ETERNIT”: 41.4 kWp, installed on a municipal warehouse (type "fully integrated"): 100% sale of energy;
 - “MAGAZZINO-SHELTER”: 29.0 kWp, installed on the roof of a municipal warehouse (type "fully integrated"): 100% sale of energy;
 - “PALAZZETTO”: 52.4 kWp, installed on the sports hall (type "partially integrated"): 100% sale of energy;
- Granted loan: about € 490,000 - 100% coverage of the investment to be realized.

8

CHECK LIST - **How a sustainable energy project can be made bankable**

In order to be bankable, a sustainable energy project needs to present some precise features.

The overall presentation

Essential conditions to make a good impression to a bank are a clear identification of the investors and a clear idea of the project. Indeed, for a financial institution it's important to know who they are going to finance and to see that the investor is well aware of the objective the business wants to reach.

A list of the main aspects about the project and the investors is listed in the following table.

Who?	<ul style="list-style-type: none">• Project Stakeholders (investor, suppliers, customers, etc ..)• Management and Key Team Members• Technology and “productive” business
What?	<ul style="list-style-type: none">• Required Resources• Supporting Raw Materials• Expected Results
Why?	<ul style="list-style-type: none">• Overall project concept ... what added value?• Market opportunity (and competitive alternatives)• Development program• Manufacturing
How?	<ul style="list-style-type: none">• Marketing• Selling function• Distribution
Where?	<ul style="list-style-type: none">• Country and Law
When?	<ul style="list-style-type: none">• Timeline

The investor

A focus on the investor is always done by the financial institution, linking its profile with the kind of project is being submitted.

The preferable situation is the presence of a strong industrial background directly by the investor or, in case for examples of Local Governments, by the private companies involved in the business. Skill and know-how in the sector of investment are also two important conditions to build a partnership of investors with enough experience to fight possible negative events during the lifetime of the project.

A co-participation in the investment (presence of “Equity”) by the investor is preferable and is a sign of common commitment.

The investment.

The precise evaluation of investment costs is an important activity that is usually underestimated: a wrong check of costs may lead to forget some expenses. For examples some to be taken into account are land, technology, electrical works, civil works, connection, dismantle costs, contingency and intangible assets (notary, advisory, taxes, bank fees, development, etc..)

Which risks?

A wrong investment is a negative scenario for both investor and financing institution: this is why the assessment of risks is one of the activities that must be taken into consideration by both parties. The changes that can occur during the lifetime of a loan are usually more than we think: it's necessary that these possible changes are studied *before* they take place and not *when* they take place.

Possible mitigations of the risks should always be considered and this may lead to a lower estimation of revenues, higher operational costs, possible delays in project pipeline, etc..

The main idea under this kind of analysis is that the investor and the financing institution are partner in business and must have all variables under control, during the whole duration of the loan.

Example of risks and mitigations can be the following.

- the Regulatory risk consisting in an uncertain legal framework (eg: change in

- value of incentives) can be faced with a precautionary business plan,
- the Construction risk consisting in delays and rise of costs can be considered in an all-inclusive EPC contract (presence of penalties for delays),
 - the Operational risk consisting in rise of operational costs or accidents can be considered in an all-inclusive O&M contracts (purchase of raw materials at certain prices),
 - the Market risk consisting in changes of price/volume of goods can be solved through precise purchasing contracts,
 - the Technical risk consisting in changes of plant efficiency can be driven through performance bond contracts,
 - the Permits/Authorization risk consisting in delays or failure in the business authorizing process should be challenged mainly by the investor. Usually the loan is given after permits or under particular guarantees,
 - the Financial risk consisting in the rise of the variable interest rate is solved by signing hedging contracts,
 - the Environmental risk consisting in the pollution or land exploitation should be studied along with experts and the involvement of the community

The final Business Plan

The possible economic and financial scenarios of the investment are presented through the business plan. It's important that all revenues (sell of goods and services, feed – in tariffs, other contributions), costs (maintenance, insurance, land lease/rent, administrative costs and personnel, connection and contingency) and other costs (financial costs and taxes) are taken in consideration.

The business plan should not be just a complete and a “correct” business plan but should demonstrate an economic and financial sustainability of the investment when stressed. This means turning the possible risks (eg: 1 month plant breakdown due to unreliable technology) into consequences in the business plan (eg: lower revenues).

One of the main outcomes to be pursued are the positive cash flows: these flows must always be high enough in order to repay all the debts.

Other useful financial indicators are the following:

- Net Present Value (NPV): the NPV is defined as the sum of the present values (PVs) of the individual (or annual) cash flows. The NPV must be higher than 0.: this means that the investment has a “reason to be done”.
- Internal Rate of Return (IRR): the IRR is a rate of return used to measure and compare the profitability of investments. It’s the annualized effective compounded return rate or discount rate that makes the net present value of all cash flows equal to zero. The IRR must be higher than the loan interest rate: this means that the investment is generating a profit event when the debts are repaid.
- Debt Service Cover Ratio (DSCR): the DSCR is the ratio of cash available for debt servicing to interest, principal and lease payments. The DSCR must be higher than a value that can vary according to the sector risk; it must always be higher than 1, meaning that the cash flows are enough to repay all debts.

SOURCES

- <http://www.bmwi.de/>
- <http://www.campagnaseeitalia.it>
- http://www.comune.vicchio.fi.it/opencms/opencms/Contenuti/Categoria_Principale/Evento_3796.html?pagename=1996
- <http://www.conorzioenergiatoscana.it/home.html>
- <http://www.decc.gov.uk/>
- http://ec.europa.eu/energy/intelligent/projects/index_en.htm
- http://ec.europa.eu/environment/etap/inaction/policynews/535_en.html
- http://ec.europa.eu/regional_policy/funds/feder/index_it.htm
- http://www.eib.org/attachments/thematic/jessica_2008_it.pdf
- <http://www.eib.org/projects/publications/jessica.htm?lang=-en>
- http://www.eib.org/products/technical_assistance/elena/index.htm
- http://www.eib.org/products/technical_assistance/jaspers/index.htm
- http://www.eticamente.altervista.org/Documenti/failasceltagiusta/ESCO/ENEA_ftp.pdf
- http://www.eumayors.eu/home_en.htm
- <http://www.eusew.eu/>
- http://www.fiditoscana.it/fondi_pubb/fdoenrin/dd4215_08.pdf
- <http://www.fire-italia.it/caricapagine.asp?target=esco/esco.asp>
- <http://www.idea.gov.uk/idk/aio/973322>
- <http://www.jaspers-europa-info.org/index.php/projects.html>
- <http://www.kfw-formularsammlung.de/>
- <http://www.managenergy.net/gp.html>
- http://www.minambiente.it/opencms/export/sites/default/archivio/allegati/vari/bando_sole_enti_publici.pdf
- http://www.minambiente.it/opencms/opencms/home_it/showitem.html?lang=it&item=/documenti/notizie/notizia_0183.xml
- <http://www.mpscapitalservices.it/Imprese/InvestimentiStrutturali/Project+financing.htm>
- <http://www.mpscommercialeleasing.it/LeasingImmobiliare/Leasing+Enti+Publici.htm>
- <http://www.regione.toscana.it/sportelloenergia/utenti/pa/index.html>
- <http://www.sustenergy.org/>
- <http://www.thamesweyenergy.co.uk>
- <http://www.woking.gov.uk/planning/service/publications/energy.pdf>